

# HÄFELE CONCEALED CISTERNS



For the first time ever, Hafele introduces a unique solution for WC units in the form of concealed water cistern that not only provides international functionality but also enables flexible and space-saving design possibilities within contemporary bathrooms. The entire cistern is ably concealed behind one of the lavatory walls with only a Flush (or actuator) plate visible on the front – thus keeping the modern and elegant look of a bathroom intact. The available space above the WC unit can be used to create artistic wall renditions that complement the overall design of the bathroom.



## PNEUMATIC CONCEALED CISTERNS

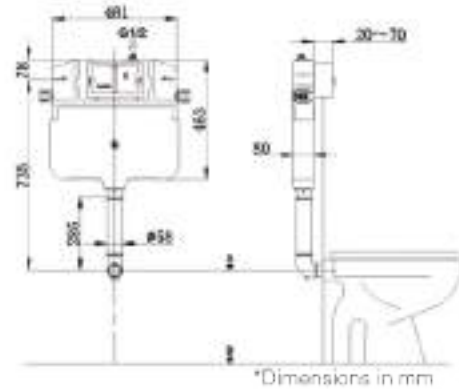

Pneumatic Concealed Cistern  
Article No : 588.73.911

### Features:

- Dual Induction Technology (separate air chambers for Half and Full flush).
- Remote flush plate installation option (Flexibility of 2 meter).
- Thinnest design (80mm thickness).
- Long service life - Tested for more than 2,00,000 cycles.
- Top quality tank material (Grade 16 - HDPE).
- Practically Noiseless refilling (European Certification).
- 6L/3L adjustable flush volumes.
- In-built Stainless steel filter to block debris from entering the tank.

### Scope of delivery:

- Cistern
- Protection box for installation (Extension box)
- Flush pipe



Luxe - P01  
Article No : 588.73.580



Luxe - P02  
Article No : 588.73.563



Luxe - P03  
Article No : 588.73.582



MECHANICAL CONCEALED CISTERNS

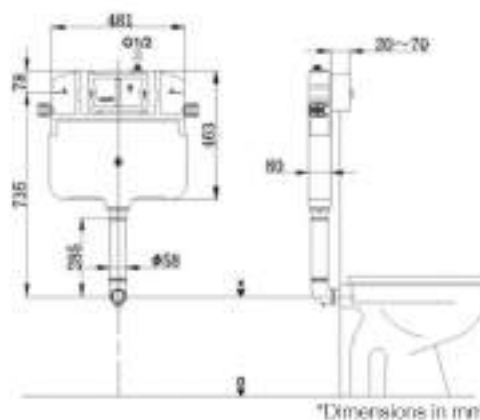

Mechanical Concealed Cistern  
Article No : 588.73.910

Features:

- Thinnest design (80mm thickness), best suited to Indian Households.
- Long service life – Tested for more than 2,00,000 cycles.
- Smooth operation, powerful flushing.
- Top quality tank material (Grade 16 - HDPE).
- Practically Noiseless refilling (European Certification).
- 6L/3L adjustable flush volumes.
- Simple installation. Easy, hassle-free maintenance.
- In-built Stainless steel filter to block debris from entering the tank.

Scope of delivery:

- Cistern
- Protection box for installation (Extension box)
- Flush pipe



Elegant - M01  
Article No : 588.73.500



Elegant - M02  
Article No : 588.73.501



Luxe - M01  
Article No : 588.73.540



Luxe - M02  
Article No : 588.73.523



Luxe - M03  
Article No : 588.73.542



Sturdy



Ease of Installation



Long Life



Increases Accuracy

Cistern Full Frame  
Article No : 588.73.989

### FEATURES:

- ▶ Compatible with both Häfele Concealed Cisterns - Mechanical and Pneumatic Front actuation
- ▶ Easy to install on Dry or solid walls
- ▶ Increases accuracy and alignment while installation of Wall Hung toilet
- ▶ Tested as per AFNOR Certification Number NF017 for 400 Kg of load bearing capacity
- ▶ Powder coated frame ensures superior quality and long life
- ▶ Flexibility to adjust the wall hung centre distance between 180 mm & 230 mm
- ▶ Frame supplied with WC connection set, M12 fixation rods for wall hung toilets and discharge bend